



MNP



TG **TONINATO** **GIORGIO**
di Rigato Claudia & C. s.n.c.

Via Villanova, 77/b - 35020 Villatora di Saonara (PD)
C.F. e P.I.: 04435930286 - E-mail: info@toninatogiorgio.it

Tel. 049 8791358
Fax 049 640725

NP Series
VALVE REGULATED LEAD-ACID BATTERIES



NP

RELIABILITY IS YOUR SECURITY

Yuasa NP, NPC and NPH Batteries Utilising the latest advance design Oxygen Recombination Technology, Yuasa have applied their 80 years experience in the lead acid battery field to produce the optimum design of Sealed Lead Acid batteries.

FEATURES

- Superb recovery from deep discharge.
- Electrolyte suspension system.
- Gas Recombination.
- Multipurpose: Float or Cyclic use.
- Usable in any orientation (except continuous inverted).
- Superior energy density.
- Lead calcium grids for extended life.
- Manufactured World wide.
- Application specific designs.

Technical Features

Sealed Construction

Yuasa's unique construction and sealing technique ensures no electrolyte leakage from case or terminals

Electrolyte Suspension System

All NP batteries utilize Yuasa's unique electrolyte suspension system incorporating a microfine glass mat to retain the maximum amount of electrolyte in the cells. The electrolyte is retained in the separator material and there is no free electrolyte to escape from the cells. No gels or other contaminants are added.

Control of Gas Generation

The design of Yuasa's NP batteries incorporates the very latest oxygen recombination technology to effectively control the generation of gas during normal use.

Low Maintenance Operation

Due to the perfectly sealed construction and the recombination of gasses within the cell, the battery is almost maintenance free.

Terminals

NP batteries are manufactured using a range of terminals which vary in size and type. Please refer to details as shown.

Operation in any Orientation

The combination of sealed construction and Yuasa's unique electrolyte suspension system allows operation in any orientation, with no loss of performance or fear of electrolyte leakage. (Excluding continuous use inverted)

Valve Regulated Design

The batteries are equipped with a simple, safe low pressure venting system which releases excess gas and automatically reseals should there be a build up of gas within the battery due to severe overcharge. Note. On no account should the battery be charged in a sealed container.

Terminals

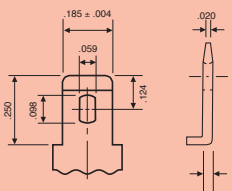
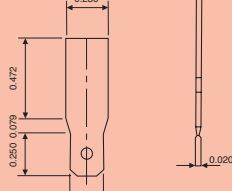
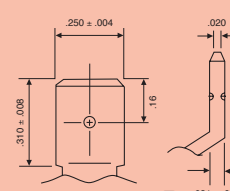
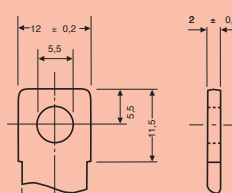
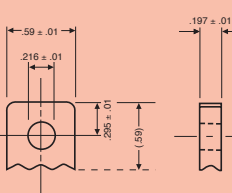
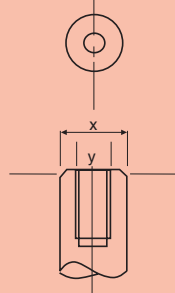
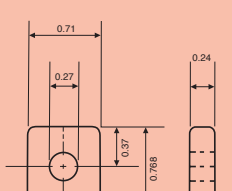
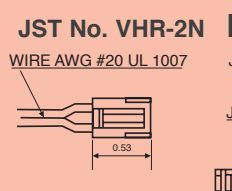
 <p>Faston tab: 187 A</p> <table border="1"> <thead> <tr> <th colspan="2">INCH = MM</th> </tr> </thead> <tbody> <tr><td>.250</td><td>6.35</td></tr> <tr><td>.185</td><td>4.70</td></tr> <tr><td>.124</td><td>3.15</td></tr> <tr><td>.098</td><td>2.50</td></tr> <tr><td>.059</td><td>1.50</td></tr> <tr><td>.031</td><td>0.80</td></tr> <tr><td>.020</td><td>0.50</td></tr> <tr><td>.004</td><td>0.10</td></tr> </tbody> </table>	INCH = MM		.250	6.35	.185	4.70	.124	3.15	.098	2.50	.059	1.50	.031	0.80	.020	0.50	.004	0.10	 <p>Faston tab: 187 B</p> <table border="1"> <thead> <tr> <th colspan="2">INCH = MM</th> </tr> </thead> <tbody> <tr><td>0.472</td><td>12.00</td></tr> <tr><td>0.250</td><td>6.35</td></tr> <tr><td>0.236</td><td>6.00</td></tr> <tr><td>0.185</td><td>4.70</td></tr> <tr><td>0.079</td><td>2.00</td></tr> <tr><td>0.020</td><td>0.50</td></tr> </tbody> </table>	INCH = MM		0.472	12.00	0.250	6.35	0.236	6.00	0.185	4.70	0.079	2.00	0.020	0.50	 <p>Faston tab: 250 D</p> <table border="1"> <thead> <tr> <th colspan="2">INCH = MM</th> </tr> </thead> <tbody> <tr><td>.310</td><td>7.90</td></tr> <tr><td>.250</td><td>6.35</td></tr> <tr><td>.16</td><td>4.0</td></tr> <tr><td>.031</td><td>0.8</td></tr> <tr><td>.020</td><td>0.5</td></tr> </tbody> </table>	INCH = MM		.310	7.90	.250	6.35	.16	4.0	.031	0.8	.020	0.5
INCH = MM																																														
.250	6.35																																													
.185	4.70																																													
.124	3.15																																													
.098	2.50																																													
.059	1.50																																													
.031	0.80																																													
.020	0.50																																													
.004	0.10																																													
INCH = MM																																														
0.472	12.00																																													
0.250	6.35																																													
0.236	6.00																																													
0.185	4.70																																													
0.079	2.00																																													
0.020	0.50																																													
INCH = MM																																														
.310	7.90																																													
.250	6.35																																													
.16	4.0																																													
.031	0.8																																													
.020	0.5																																													
 <p>Bolt fastened terminal E</p> <table border="1"> <thead> <tr> <th colspan="2">INCH = MM</th> </tr> </thead> <tbody> <tr><td>.472</td><td>12.00</td></tr> <tr><td>.453</td><td>11.50</td></tr> <tr><td>.433</td><td>11.00</td></tr> <tr><td>.216</td><td>5.50</td></tr> <tr><td>.079</td><td>2.00</td></tr> </tbody> </table>	INCH = MM		.472	12.00	.453	11.50	.433	11.00	.216	5.50	.079	2.00	 <p>Bolt fastened terminal F</p> <table border="1"> <thead> <tr> <th colspan="2">INCH = MM</th> </tr> </thead> <tbody> <tr><td>.59</td><td>15.0</td></tr> <tr><td>.216</td><td>5.5</td></tr> <tr><td>.295</td><td>7.5</td></tr> <tr><td>.197</td><td>5.0</td></tr> </tbody> </table>	INCH = MM		.59	15.0	.216	5.5	.295	7.5	.197	5.0	<p>Internal thread terminal</p>  <table border="1"> <thead> <tr> <th>Terminal</th> <th>x</th> <th>y</th> </tr> </thead> <tbody> <tr> <td>J:</td> <td>17mm</td> <td>M5</td> </tr> <tr> <td>K:</td> <td>20mm</td> <td>M6</td> </tr> <tr> <td>L:</td> <td>20mm</td> <td>M8</td> </tr> </tbody> </table>	Terminal	x	y	J:	17mm	M5	K:	20mm	M6	L:	20mm	M8										
INCH = MM																																														
.472	12.00																																													
.453	11.50																																													
.433	11.00																																													
.216	5.50																																													
.079	2.00																																													
INCH = MM																																														
.59	15.0																																													
.216	5.5																																													
.295	7.5																																													
.197	5.0																																													
Terminal	x	y																																												
J:	17mm	M5																																												
K:	20mm	M6																																												
L:	20mm	M8																																												
 <p>Bolt fastened terminal G</p> <table border="1"> <thead> <tr> <th colspan="2">INCH = MM</th> </tr> </thead> <tbody> <tr><td>0.24</td><td>6</td></tr> <tr><td>0.27</td><td>7</td></tr> <tr><td>0.37</td><td>9.5</td></tr> <tr><td>0.71</td><td>18</td></tr> <tr><td>0.768</td><td>19.5</td></tr> </tbody> </table>	INCH = MM		0.24	6	0.27	7	0.37	9.5	0.71	18	0.768	19.5	<p>JST No. VHR-2N I</p> <p>WIRE AWG #20 UL 1007</p>  <p>JST No. VHR-2N (TERMINAL) JST SVH-21T-P1.1</p>																																	
INCH = MM																																														
0.24	6																																													
0.27	7																																													
0.37	9.5																																													
0.71	18																																													
0.768	19.5																																													

Lead Calcium Grids

The heavy duty lead calcium alloy grids provide an extra margin of performance and life in both cyclic and float applications and give unparalleled recovery from deep discharge.

Long Cycle Service Life

Depending upon the average depth of discharge, over a thousand discharge/charge cycles can be expected.

Float Service Life

The expected service life is five years in float standby applications.

Separators

The use of the special separator material provides a very efficient insulation between plates preventing inter-plate short circuits and prohibiting the shedding of active materials.

Long shelf Life

The extremely low self discharge rate allows the battery to be stored for extended periods up to one year at normal ambient temperatures with no permanent loss of capacity.

Operating Temperature Range

The batteries can be used over a broad temperature range permitting considerable flexibility in system design and location.

Charge – 15°C to 50°C

Discharge – 20°C to 60°C

Storage – 20°C to 50°C (fully charged battery)

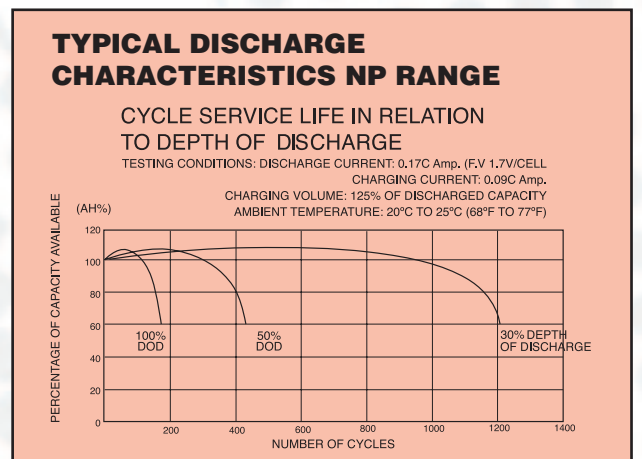
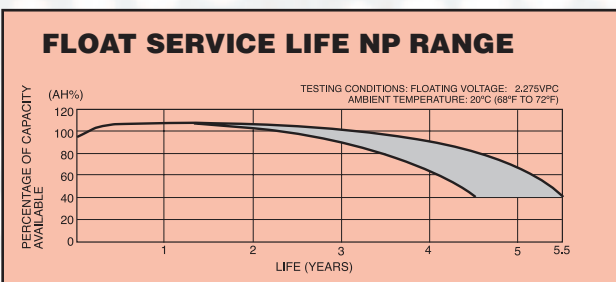
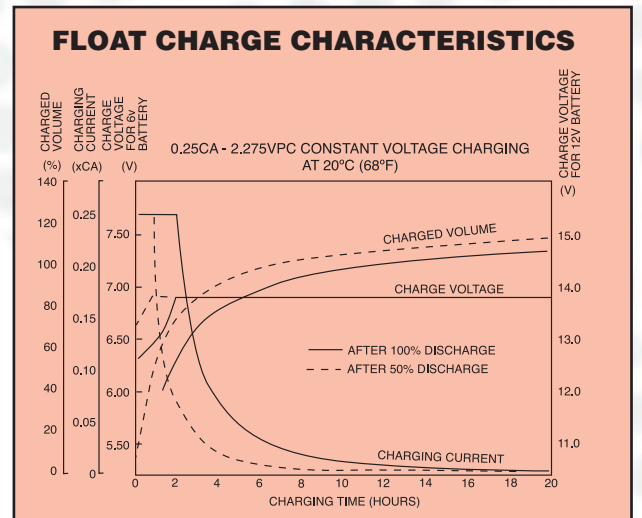
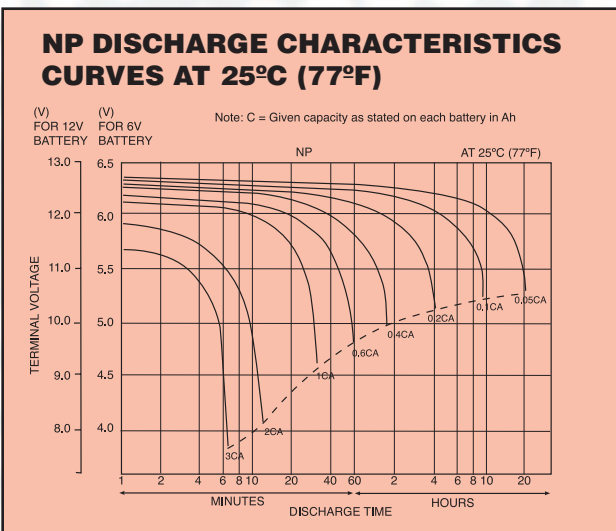
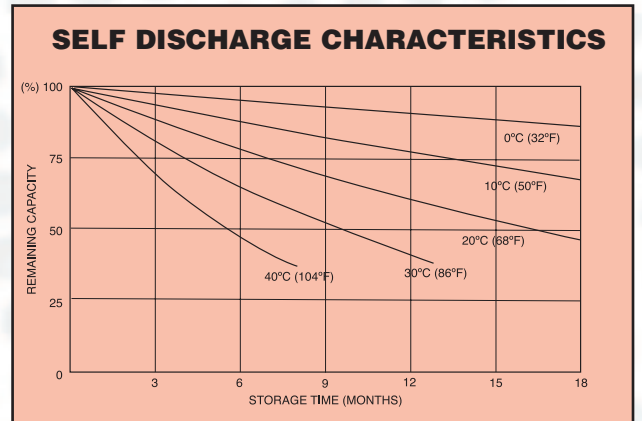
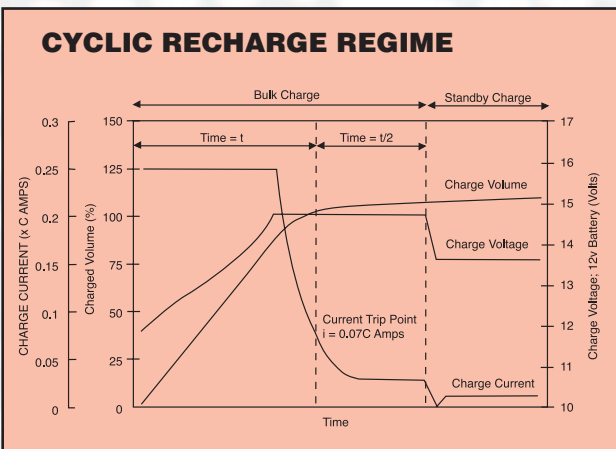

INTELLIGENT BATTERY CHARGERS

Manufactured to BS3456, IEC335, UL 1236, EN60335, CE mark to EN5008-1

Features

Micro processor controlled
 Short circuit protection
 Reverse polarity protection
 High temperature protection
 Soft start current control
 Fast constant current bulk charge
 3 stage charging CI-CV-float
 Constant voltage float/standby
 Proportional timing
 Flexibility, to match battery specification.

Standard Range

YCP03A12	300mA 12v
YCP03A24	300mA 24v
YCP03A6	300mA 6v
YCP06A12	600mA 12v
YCP06A6	600mA 6v
YCP1.5A12	1.5A 12v
YCP1.5A24	1.5A 24v
YCP1.5A6	1.5A 6v
YCP1A12	1A 12v
YCP1A6	1A 6v
YCP2A12	2A 12v
YCP2A24	2A 24v
YCP2A6	2A 6v
YCP3A12	3A 12v
YCP4A12	4A 12v
YCP6A12	6A 12v
YCP8A12	8A 12v
YCP10A12	10A 12v
YCP8A24	8A 24v

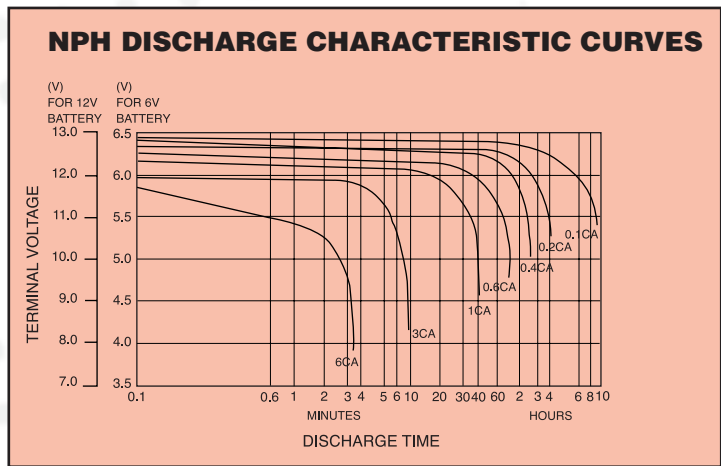

Standard NP

Available in a wide range of sizes to suit general applications.

NPH/NPW

High performance batteries specially designed for applications requiring high rate discharge, supplying up to 50% (NPH), (NPW) more power (Watts) for short durations when compared to conventional NP models.

NPC

Specifically designed to suit the arduous requirements of cyclic applications allowing increased cycle life (at least double that of conventional types). (NPC Shortform refers)

NPL

Long Life Model also to BS6290pt4 (FR Options)
 Dedicated literature available on request. (NPL Shortform refers).

Applications

Yuasa NP batteries, having excellent deep discharge recovery characteristics coupled with long life on float standby, are ideal for numerous applications in both cyclic and standby modes. For advice on the use of NP batteries in your particular application please contact our Sales Office.

Charging For Float Standby Applications

Charged at 2.275 volts per cell continuous. The battery will seek its own current level and float fully charged. However, users should be aware that when charging from fully discharged, the battery can draw an initial charge current of approximately 2cA. Care should therefore be taken to ensure that this initial charge current (if uncontrolled) is within the output capability of the equipment. Final charge current at 2.275 volts per cell is typically between 0.0005cA to 0.004cA.

Charging For Cyclic Applications

See cyclic recharge regime graph.

CAUTION

- Do not Short Circuit
- Do not charge in a sealed container
- Service life and operational characteristics will be affected by temperature
- AC Ripple reduces service life.

WARNING!

The battery type NP65-12I must never be installed permanently suspended by their handles; they are not designed for this purpose.

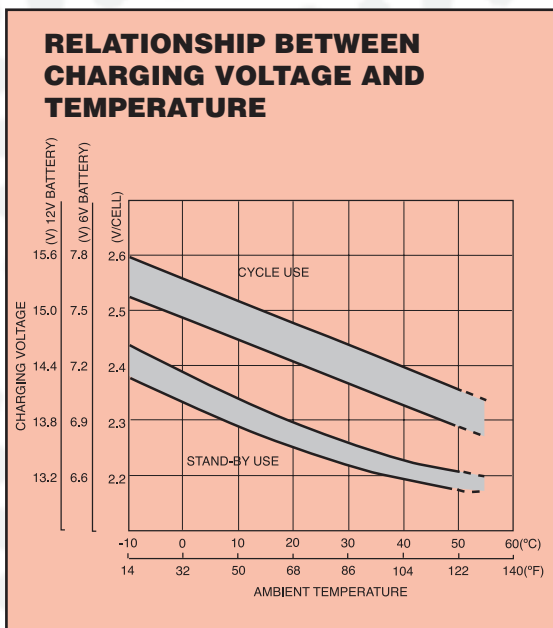

General Specifications

Nominal Capacity (Ah)	NP1-6	NP1.2-6	NP2.8-6	NP4-6	NP7-6	NP10-6	NP12-6	NP0.8-12	NP1.2-12	NP2-12	NP2.1-12	NP2.3-12	NP2.8-12	NP3.2-12
20hr to 1.75vpc 30°C	1	1.2	2.8	4	7	10	12	0.8	1.2	2	2.1	2.3	2.8	3.2
10hr to 1.75vpc 20°C	0.93	1.1	2.5	3.7	6.5	9.2	11.1	0.74	1.1	1.86	1.9	2.1	2.5	2.9
5hr to 1.70vpc 20°C	0.85	1	2.3	3.4	6	8.5	10	0.68	1	1.7	1.75	1.9	2.3	2.7
1hr to 1.60vpc 20°C	0.6	0.7	1.6	2.4	4.2	6	7.2	0.48	0.7	1.2	1.2	1.3	1.6	1.9
Voltage	6	6	6	6	6	6	6	12	12	12	12	12	12	12
Energy Density (Wh.L.20hr)	54	58	61	72	86.2	85	101	65	61	95	69	76	63	71
Specific Energy (Wh.kg.20hr)	24	25	29	28	28.5	30	35	27	25	34	31	29	30	32
Int. Resistance (m.Ohms)	75	60	30	20	22.5	8	8	270	110	180	60	65	60	50
Maximum discharge (A)	5	12	28	40	35	40/75	75	4	12	10	21	23	28	32
Short Circuit current (A)	15	36	84	1.20	105	300	360	12	36	30	63	69	84	96
Dimensions (mm)														
Length	51	97	134	70	151	151	151	96	97	150	178	178	134	134
Width	42.5	25	34	47	34	50	50	25	48	20	34	34	67	67
Height overall	54.5	54.5	64	105.5	97.5	97.5	97.5	61.5	54.5	89	64	64	64	64
Weight (Kg)	0.25	0.31	0.57	0.87	1.32	1.93	2.05	0.35	0.58	0.7	0.82	0.95	1.12	1.2
Terminal	A	A	A	A	A	A/D	D	I	A	B	A	A	A	A
Layout	5	1	1	5	1	1	1	6	3	7	1	1	3	3
Terminal Torque Nm	-	-	-	-	-	-	-	-	-	-	-	-	-	-

Nominal Capacity (Ah)	NP4-12	NP7-12	NP12-12	NP17-12I	NP18-12	NP24-12I	NP38-12I	NP65-12I	NPH2-12FR	NPH3.2-12	NPH5-12	NPH12-12	NPW45-12
20hr to 1.75vpc 30°C	4	7	12	17	17.2	24	38	65	-	-	-	-	29wpc 15min
10hr to 1.75vpc 20°C	3.7	6.4	11.1	15.7	16	22.3	35.3	60.5	2	3.2	5	12	40wpc 10min
5hr to 1.70vpc 20°C	3.4	5.9	10	14.4	14.5	20.4	32.3	55.3	1.82	2.91	4.5	10.8	63wpc 5min
1hr to 1.60vpc 20°C	2.4	4.2	7.2	10.2	10.3	14.4	22.8	39	1.5	2.4	3.8	9	82wpc 3min
Voltage	12	12	12	12	12	12	12	12	12	12	12	12	12
Energy Density (Wh.L.20hr)	75	91	104	89	94	79	83	77	82.7	69.2	92.9	95	89.7
Specific Energy (Wh.kg.20hr)	27	32	36	33	38	32	32	34	28.5	27.3	29.9	32	30.7
Int. Resistance (m.Ohms)	40	25	16	15	11	9.5	7.5	5	66	35	24	16	-
Maximum discharge (A)	40/75	40/75	75	170	112	240	300	500	14	22.4	35	84	42
Short Circuit current (A)	120	210	360	500	500	500	500	800	40	64	100	240	105
Dimensions (mm)													
Length	90	151	151	181	180	166	197	350	68	134	90	151	151
Width	70	65	98	76	76	175	165	166	51	67	70	98	65
Height overall	106	97.5	97.5	167	167	125	170	174	88	64	106	97.5	97.5
Weight (Kg)	1.75	2.65	4.05	6.1	6.2	9	14.2	23	0.84	1.4	2	4.2	2.7
Terminal	A/D	A/D	D	J	E	J	J	K	A	A	D	D	D
Layout	1	4	4	2	2	2	2	2	2	3	1	4	4
Terminal Torque Nm	-	-	-	2.45	-	2.45	2.45	4.76	-	-	-	-	-

Layouts

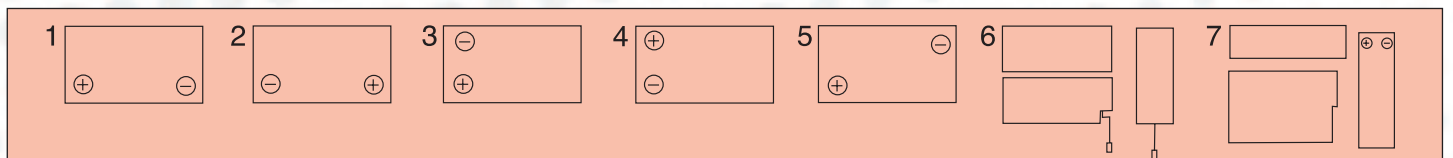



NPC



NPC Series

VALVE REGULATED LEAD-ACID BATTERIES
CYCLIC APPLICATION

NPC

YUASA NPC SERIES

The low maintenance and valve regulated constructions combine with heavy-duty plates and unique separator systems to make NPC service twice as long as conventional counterparts.

FEATURES

1. Double cycle life

NPC operates 500 charge/discharge cycles or twice as many cycles as conventional cycle use batteries at 75%D.O.D. (depth of discharge).

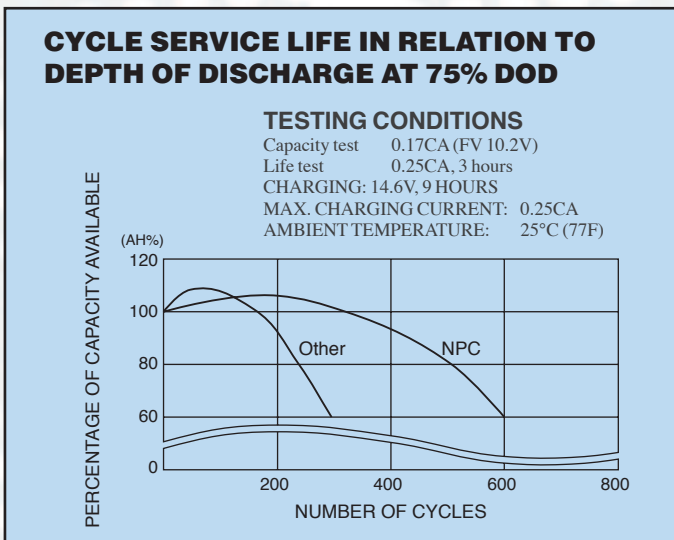

2. Valve-regulated and maintenance-free

Battery electrolyte retained solidly in the separator and the innovative gas recombinant system allows minimum gas emittance freeing the user from maintenance.

3. Durability for deep discharge use

Yuasa's state-of-the-art plate barrier prevention and the unique separator systems help endure deep discharge use thus considerably prolonging battery's service life.

4. Minimal self-discharge

Cyclic use batteries tend to be left discharged after usage causing plate corrosion leading to shortened life. Self discharge rate of NPC is as small as only 0.1% a day at 20°C and thus extends the storage period allowed.

Operating temperature range

Charge:	- 15 ~ 50°C	(5 ~ 122°F)
Discharge:	- 15 ~ 50°C	(5 ~ 122°F)
Storage:	- 20 ~ 50°C	(- 4 ~ 122°F)

Recommended charging method

Current:	Max. 0.25CA
Voltage:	2.4 ~ 2.5VPC

Applications

- Wheelchairs
- Golf trolley
- Professional Electric Tools
- Emergency Lighting
- Mobility Scooters
- Sprayers
- Photovoltaics
- Industrial applications
- Communications
- Lifts
- Pumps
- Measuring instruments
- AGV (Automatic guided vehicle)
- Magnetic lifts

Specifications

NPC Model	Volts	Rated Capacity (20 hr rate) (Ah)	Approx. Dimensions			Weight	Layout	Terminals
			Length	Width	Overall height incl. terminals			
NPC17 - 12	12	17	181mm	76mm	167mm	6.2kg	2	E
NPC24 - 12I	12	24	175mm	166mm	125mm	8.8kg	2	J
NPC30 - 12	12	30	195mm	129mm	179mm	11.25kg	1	F
NPC38 - 12I	12	38	197mm	165mm	170mm	14kg	2	J
NPC65 - 12I	12	65	350mm	166mm	174mm	23kg	2	K

Terminals

Bolt fastened terminal F

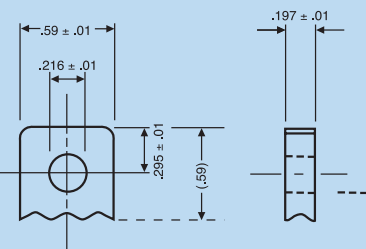

INCH = MM	
.59	15.0
.216	5.5
.295	7.5
.197	5.0

Terminals J, K & L

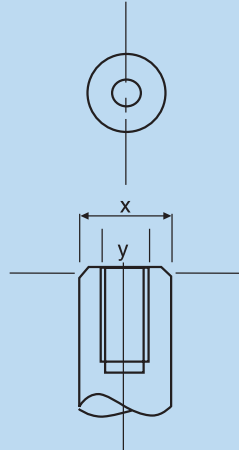

Terminal	x	y
J:	17mm	M5
K:	20mm	M6
L:	20mm	M8

Bolt fastened terminal E

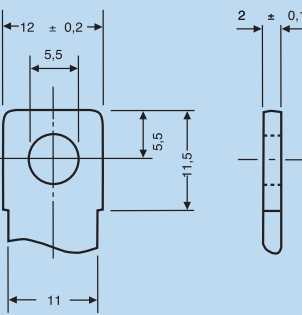

INCH = MM	
.472	12.00
.453	11.50
.433	11.00
.216	5.50
.079	2.00

Layouts

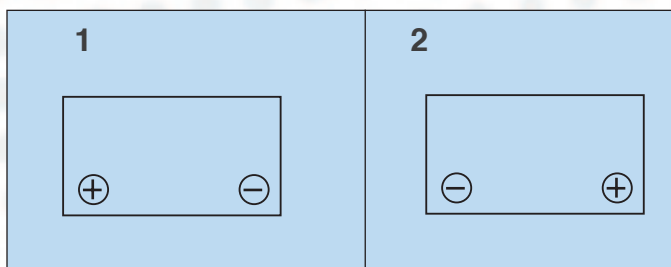

CAUTION

- Avoid short circuit.
- Do not charge in a sealed container.
- Service life and operational characteristics will be affected by temperature.
- AC Ripple reduces service life.

WARNING!

The battery type NPC65-12I must never be installed permanently suspended by their handles; they are not designed for this purpose.

Performance

CYCLE SERVICE LIFE IN RELATION TO DEPTH OF DISCHARGE

TESTING CONDITIONS

Capacity test 0.17CA (FV 10.2V)
 Life test 0.25CA, 3 hours
 CHARGING: 14.6V, 9 HOURS
 MAX. CHARGING CURRENT: 0.25CA
 AMBIENT TEMPERATURE: 25°C (77°F)

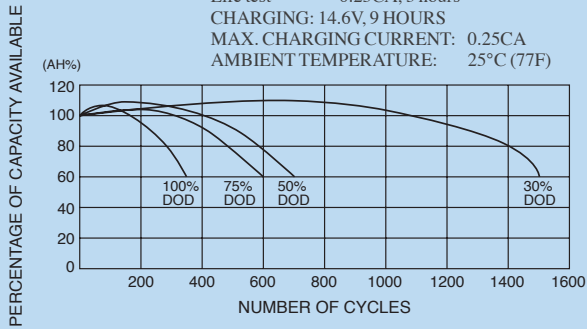

CONSTANT CURRENT, CONSTANT VOLTAGE CHARGING CHARACTERISTICS

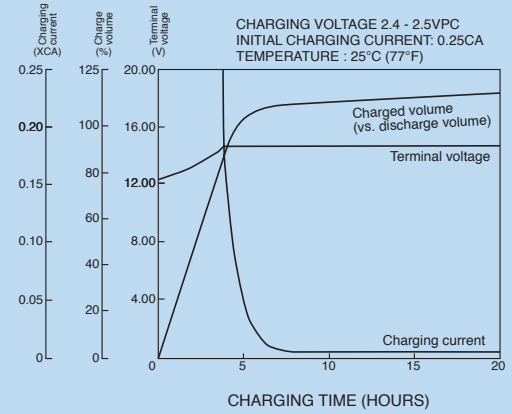

DISCHARGE CURRENT VS. DURATION TIME

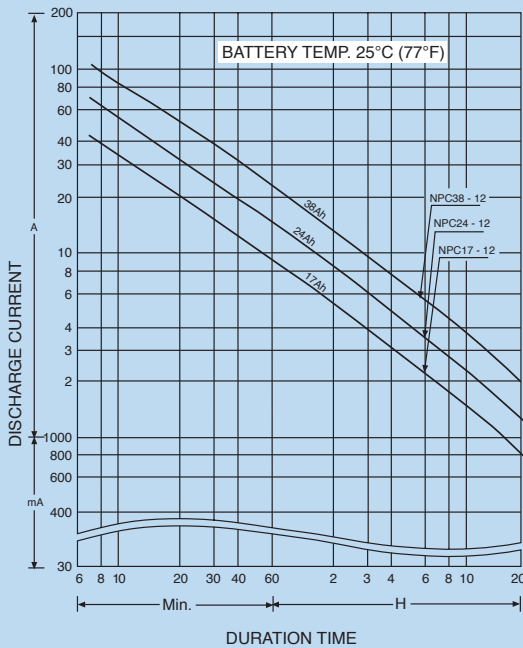

DISCHARGE CHARACTERISTICS AT VARIOUS CURRENTS (25°C (77°F))

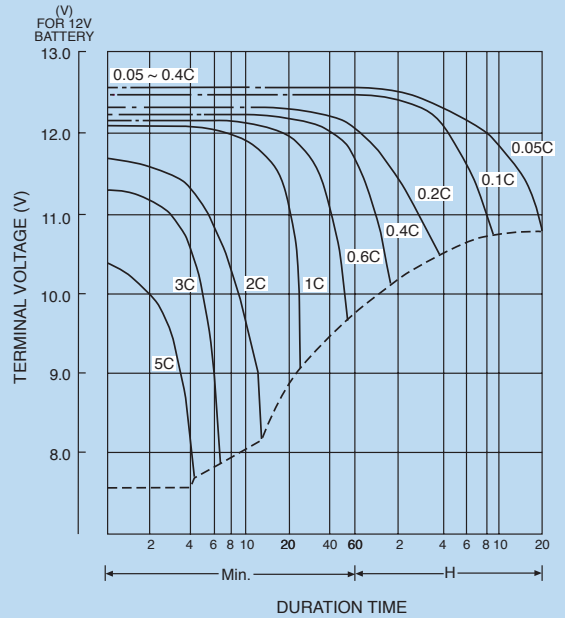

SELF DISCHARGE CHARACTERISTICS

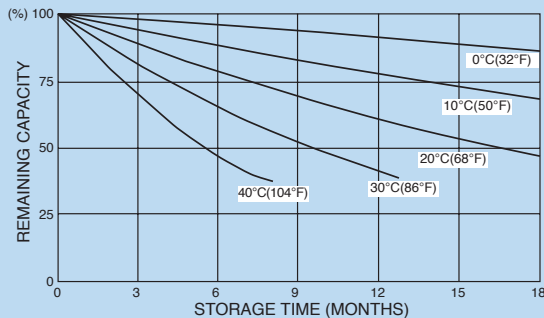

CYCLIC RECHARGE REGIME

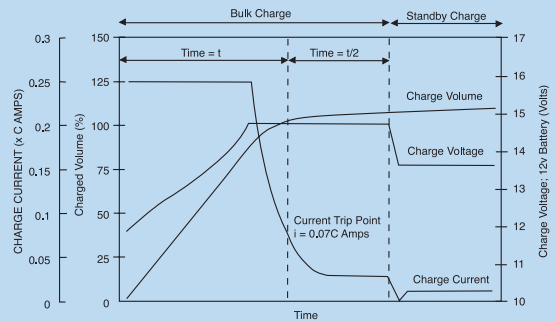

Yuasa Battery Sales (UK) Ltd

Unit 22 Rassau Industrial Estate
 Ebbw Vale, Gwent, NP23 5SD
 Tel: 08708 500312 Fax: 08708 500317
 E-mail: enquiries@yuasa-sales.co.uk

Registered number 1548820

Cat. No. NPCSF April 06

E&O.E.

Distributed by



SWL



SWL Series

VALVE REGULATED LEAD-ACID BATTERIES

SWL

SWL VALVE REGULATED LEAD-ACID BATTERIES (VRLA)

The SWL range is an enhanced NPL design resulting in an improved energy to density ratio, giving up to 40% extra discharge capacity. All other attributes and operational characteristics are the same, thereby maintaining the benefit of a common mechanical and electrical design for users of both products.

FEATURES

- Yuasa VRLA batteries can be used in any orientation excluding continuous use inverted.
- Standard case material is flame retardant to (UL94) HBØ.
- FR option case material is flame retardant to UL94:VØ (oxygen index 30).
- SWL batteries are manufactured in factories that comply with ISO9001:2000.
- FR option SWL's comply with BS6290 Part 4 (1997).
- SWL batteries comply with IEC 60896-21+22.

Layouts

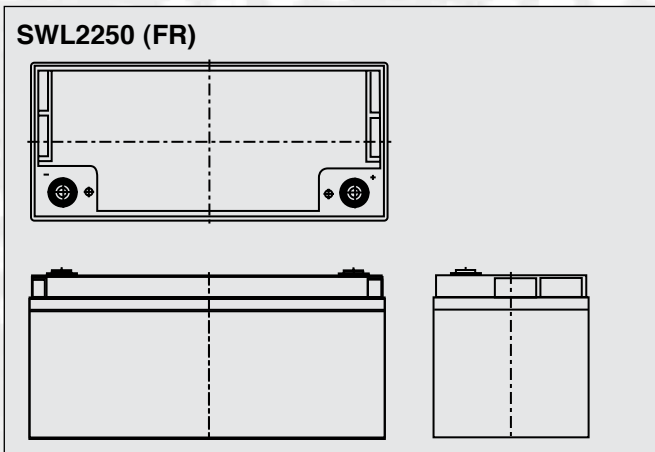
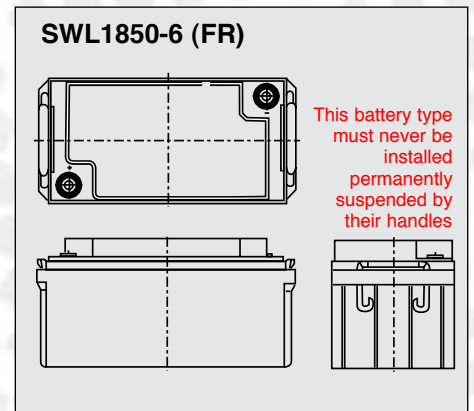
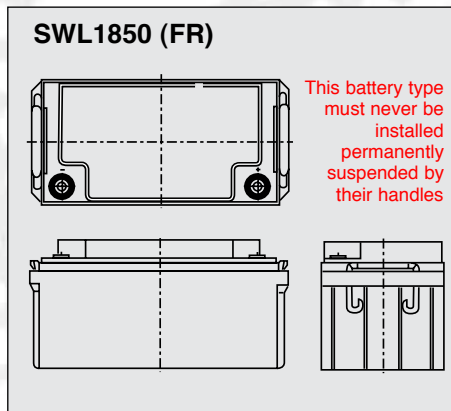
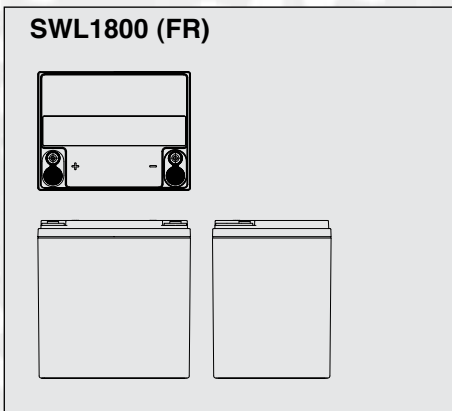
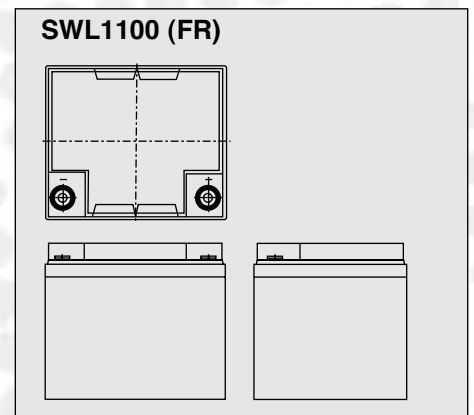
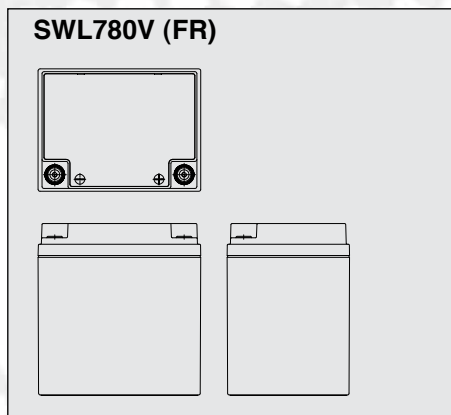
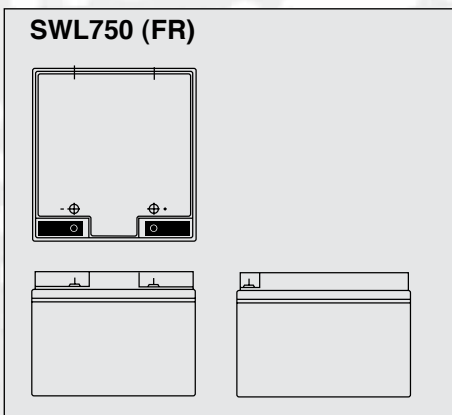

Layouts continued

SWL2300E (FR)

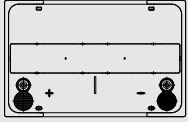

This battery type must never be installed permanently suspended by their handles

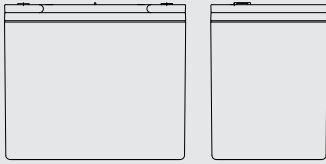

SWL2500E (FR)

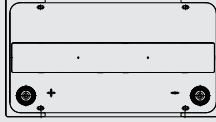

This battery type must never be installed permanently suspended by their handles

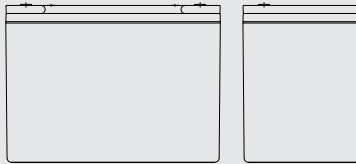

SWL2500-6 (FR)

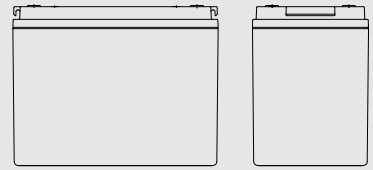
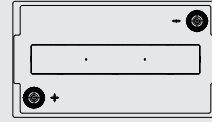

SWL2500T (FR)

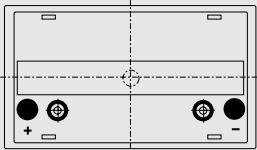

This battery type must never be installed permanently suspended by their handles

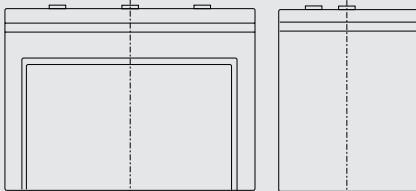

SWL3300 (FR)

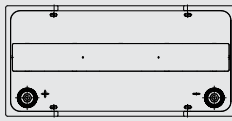

This battery type must never be installed permanently suspended by their handles



SWL3800 (FR)

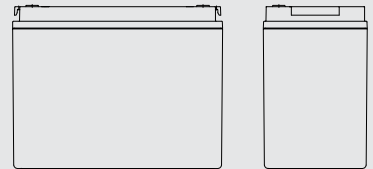
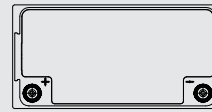

SWL4250 (FR)

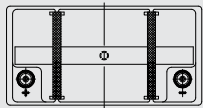

This battery type must never be installed permanently suspended by their handles

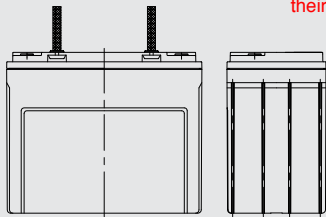

Terminals (mm)

Terminal	X	Y	L
B	17mm	M5	10
C	20mm	M6	16
D	20mm	M8	16

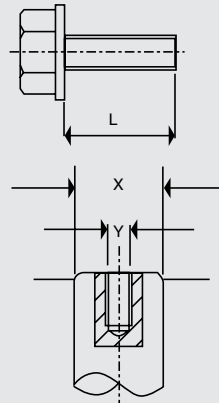

General Specifications

Specifications	SWL750 (FR)	SWL780V (FR)	SWL1100 (FR)	SWL1800 (FR)	SWL1850 (FR)	SWL1850-6 (FR)	SWL2250 (FR)
Nominal Voltage	12V	12V	12V	12V	12V	6V	12V
10-min rate Constant Power 9.6V at 20°C	750W	780W	1100W	1800W	1850W	1152W	2250W
10-min rate Constant Power 1.6V/Cell at 20°C	125W	130W	183W	300W	308W	384W	375W
10-hr rate Capacity to 10.8V at 20°C	22.9Ah	27.1Ah	39.6Ah	55Ah	66Ah	132Ah	76Ah
Dimensions / mm							
Length	166 (± 0.5)	166 (± 1)	197 (± 0.5)	216 (± 0.7)	350 (± 0.7)	350 (± 0.7)	380 (± 0.7)
Width	175 (± 0.5)	125 (± 1)	165 (± 0.5)	168 (± 0.5)	166 (± 0.5)	166 (± 0.5)	166 (± 0.5)
Height	125 (± 0.5)	175 (± 2)	170 (± 0.5)	223 (± 0.7)	174 (± 0.5)	174 (± 0.5)	174 (± 0.5)
(height over terminals)	N/A	N/A	N/A	N/A	N/A	N/A	N/A
Mass (typical) Kg	9.0	10.1	14.0	23.0	23.0	23.0	27.5
Terminal Type							
Female threaded terminal	M5	M5	M5	M6	M6	M6	M8
Torque	2.5Nm	2.5Nm	2.5Nm	4.8Nm	4.8Nm	4.8Nm	6Nm
Operating Temperature Range							
Storage (in fully charged condition) °C	-20 to +60	-20 to +60	-20 to +60	-20 to +50	-20 to +50	-20 to +50	-20 to +50
Charge °C	-15 to +50	-15 to +50	-15 to +50	-15 to +50	-15 to +50	-15 to +50	-15 to +50
Discharge °C	-20 to +60	-20 to +60	-20 to +60	-20 to +60	-20 to +60	-20 to +60	-20 to +60
Storage							
Capacity loss per month at 20°C (approx)	3%	3%	3%	3%	3%	3%	3%
Case Material							
Standard Option	ABS (UL94:HB)	ABS (UL94:HB)	ABS (UL94:HB)	ABS (UL94:HB)	ABS (UL94:HB)	ABS (UL94:HB)	ABS (UL94:HB)
Flame retardant option (FR)	ABS (UL94:VO)	ABS (UL94:VO)	ABS (UL94:VO)	ABS (UL94:VO)	ABS (UL94:VO)	ABS (UL94:VO)	ABS (UL94:VO)
Charge Voltage							
Float charge voltage at 20°C	13.65 (± 1%) V	13.65 (± 1%) V	13.65 (± 1%) V	13.65 (± 1%) V	13.65 (± 1%) V	6.825 (± 1%) V	13.65 (± 1%) V
	2.275 (± 1%) V/cell	2.275 (± 1%) V/cell	2.275 (± 1%) V/cell	2.275 (± 1%) V/cell	2.275 (± 1%) V/cell	2.275 (± 1%) V/cell	2.275 (± 1%) V/cell
Float Charge voltage temperature correction factor (for variations from the standard 20°C)	-3 mV/cell/°C	-3 mV/cell/°C	-3 mV/cell/°C	-3 mV/cell/°C	-3 mV/cell/°C	-3 mV/cell/°C	-3 mV/cell/°C
Cyclic (or Boost) charge at 20°C	14.5 (± 3%) V	14.5 (± 3%) V	14.5 (± 3%) V	14.5 (± 3%) V	14.5 (± 3%) V	7.25 (± 3%) V	14.5 (± 3%) V
	2.42 (± 3%) V/cell	2.42 (± 3%) V/cell	2.42 (± 3%) V/cell	2.42 (± 3%) V/cell	2.42 (± 3%) V/cell	2.42 (± 3%) V/cell	2.42 (± 3%) V/cell
Cyclic Charge voltage temperature correction factor (for variations from the standard 20°C)	-4 mV/cell/°C	-4 mV/cell/°C	-4 mV/cell/°C	-4 mV/cell/°C	-4 mV/cell/°C	-4 mV/cell/°C	-4 mV/cell/°C
Charge Current							
Float charge current limit	No Limit	No Limit	No Limit	No Limit	No Limit	No Limit	No Limit
Cyclic (or Boost) charge current limit	11.45A	6.78A	9.90A	13.75A	16.50A	33.00A	19.00A
Maximum Discharge Current							
1 second	500A	500A	500A	800A	800A	500A	800A
1 minute	150A	150A	200A	500A	500A	260A	500A
Short-circuit Current & Internal Resistance (according to EN IEC 60896-21)							
Internal resistance	20.47mΩ	N/A mΩ	14.4mΩ	10.09mΩ	9.35mΩ	2.96mΩ	10.49mΩ
Short-circuit current	714A	N/A A	1005A	1437A	1529A	2408A	1442A
Impedance							
Measured at 1 kHz	9.5mΩ	8.5mΩ	7.5mΩ	4mΩ	5mΩ	2.5mΩ	3.6mΩ
Design Life							
EUROBAT Classification: High Performance Years	10 to 12	10 to 12	10 to 12	10 to 12	10 to 12	10 to 12	10 to 12
Yuasa design life (at 20°C) Years	up to 10	up to 10	up to 10	up to 10	up to 10	up to 10	up to 10

General Specifications continued

Specifications	SWL2300E (FR)	SWL2500-6 (FR)	SWL2500E (FR)	SWL2500T (FR)	SWL3300 (FR)	SWL3800 (FR)	SWL4250 (FR)
Nominal Voltage	12V	6V	12V	12V	12V	12V	12V
10-min rate Constant Power 9.6V at 20°C	2300W	2600W	2500W	2500W	3300W	3800W	4250W
10-min rate Constant Power 1.6V/Cell at 20°C	383W	867W	417W	416.67W	550W	633W	708W
10-hr rate Capacity to 10.8V at 20°C	78Ah	180Ah	90Ah	90Ah	105Ah	124Ah	140Ah
Dimensions / mm							
Length	261 (± 0.7)	297 (± 1)	305 (± 0.7)	305 (± 3)	350 (± 0.7)	350 (± 1)	341 (± 3)
Width	168 (± 0.5)	168 (± 1)	168 (± 0.5)	173 (± 3)	168 (± 0.5)	173 (± 1)	173 (± 3)
Height	225 (± 0.7)	231.5 (± 2)	225 (± 0.7)	220 (± 3)	225 (± 0.7)	272 (± 2)	281 (± 3)
(height over terminals)	N/A	N/A	N/A	223 (± 3)	N/A	N/A	N/A
Mass (typical) Kg	27.0	32.5	32.0	31.0	38.0	48.0	49.0
Terminal Type							
Female threaded terminal	M6mm	M8mm	M6mm	M6mm	M8mm	M8mm	M8mm
Torque	4.8Nm	6Nm	4.8Nm	4.8Nm	6Nm	6Nm	6Nm
Operating Temperature Range							
Storage (in fully charged condition) °C	-20 to +50	-20 to +50	-20 to +50	-15 to +40	-20 to +50	-20 to +50	-20 to +50
Charge °C	-15 to +50	-15 to +50	-15 to +50	-15 to +50	-15 to +50	-15 to +50	-15 to +50
Discharge °C	-20 to +60	-20 to +60	-20 to +60	-15 to +50	-20 to +60	-20 to +60	-20 to +60
Storage							
Capacity loss per month at 20°C (approx)	3%	3%	3%	3%	3%	3%	3%
Case Material							
Standard Option	ABS (UL94:HB)	ABS (UL94:HB)	ABS (UL94:HB)	ABS (UL94:HB)	ABS (UL94:HB)	ABS (UL94:HB)	ABS (UL94:HB)
Flame retardant option (FR)	ABS (UL94:VO)	ABS (UL94:VO)	ABS (UL94:VO)	ABS (UL94:VO)	ABS (UL94:VO)	ABS (UL94:VO)	ABS (UL94:VO)
Charge Voltage							
Float charge voltage at 20°C	13.65 (± 1%) V	6.825 (± 1%) V	13.65 (± 1%) V	13.65 (± 1%) V	13.65 (± 1%) V	13.65 (± 1%) V	13.65 (± 1%) V
	2.275 (± 1%) V/cell	2.275 (± 1%) V/cell	2.275 (± 1%) V/cell	2.275 (± 1%) V/cell	2.275 (± 1%) V/cell	2.275 (± 1%) V/cell	2.275 (± 1%) V/cell
Float Charge voltage temperature correction factor (for variations from the standard 20°C)	-3 mV/cell/°C	-3 mV/cell/°C	-3 mV/cell/°C	-3 mV/cell/°C	-3 mV/cell/°C	-3 mV/cell/°C	-3 mV/cell/°C
Cyclic (or Boost) charge at 20°C	14.5 (± 3%) V	7.25 (± 3%) V	14.5 (± 3%) V	14.5 (± 3%) V	14.5 (± 3%) V	14.5 (± 3%) V	14.5 (± 3%) V
	2.42 (± 3%) V/cell	2.42 (± 3%) V/cell	2.42 (± 3%) V/cell	2.42 (± 3%) V/cell	2.42 (± 3%) V/cell	2.42 (± 3%) V/cell	2.42 (± 3%) V/cell
Cyclic Charge voltage temperature correction factor (for variations from the standard 20°C)	-4 mV/cell/°C	-4 mV/cell/°C	-4 mV/cell/°C	-4 mV/cell/°C	-4 mV/cell/°C	-4 mV/cell/°C	-4 mV/cell/°C
Charge Current							
Float charge current limit	No Limit A	No Limit A	No Limit A	No Limit A	No Limit A	No Limit A	No Limit A
Cyclic (or Boost) charge current limit	19.50A	45A	22.50A	22.5A	26.25A	31.00A	35.00A
Maximum Discharge Current							
1 second	800A	1500A	1000A	598A	1100A	1200A	840A
1 minute	400A	800A	500A	276A	550A	600A	420A
Short-circuit Current & Internal Resistance (according to EN IEC 60896-21)							
Internal resistance	7.71mΩ	N/A mΩ	6.5mΩ	5.64mΩ	5.64mΩ	4.8mΩ	N/A mΩ
Short-circuit current	1857A	N/A A	2258A	2547A	2547A	3000A	N/A A
Impedance							
Measured at 1 kHz	5.5mΩ	3mΩ	5mΩ	6mΩ	4mΩ	4mΩ	2.7mΩ
Design Life							
EUROBAT Classification: High Performance Years	10 to 12	10 to 12	10 to 12	10 to 12	10 to 12	10 to 12	10 to 12
Yuasa design life (at 20°C) Years	up to 10	up to 10	up to 10	up to 10	up to 10	up to 10	up to 10

CHARGING CHARACTERISTICS

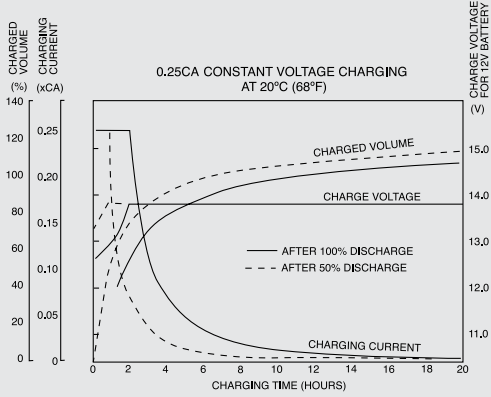

CHARGING CHARACTERISTICS

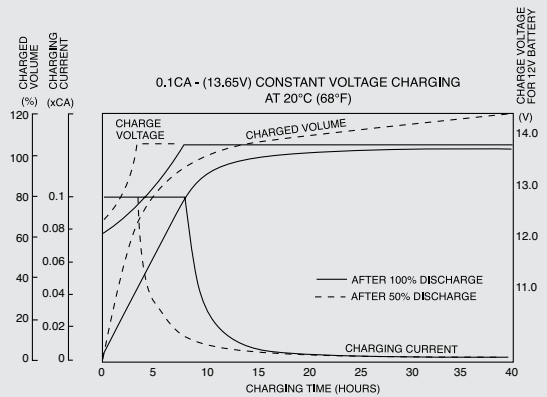

DISCHARGE CHARACTERISTIC CURVES

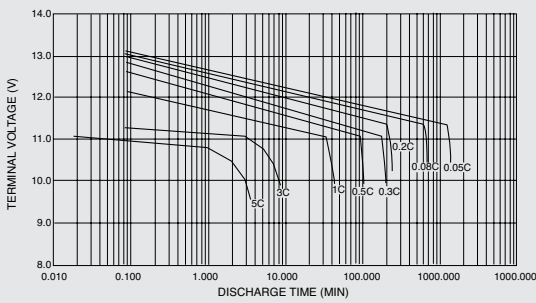

TEMPERATURE/LIFE CHARACTERISTIC

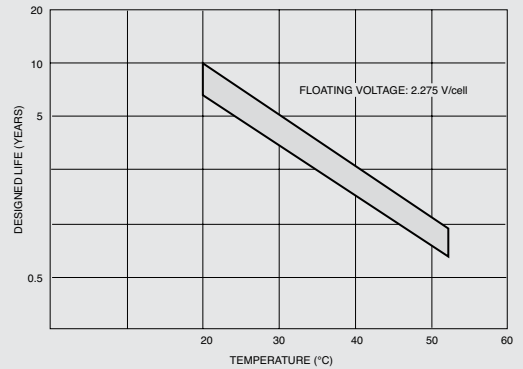

SELF DISCHARGE CHARACTERISTICS

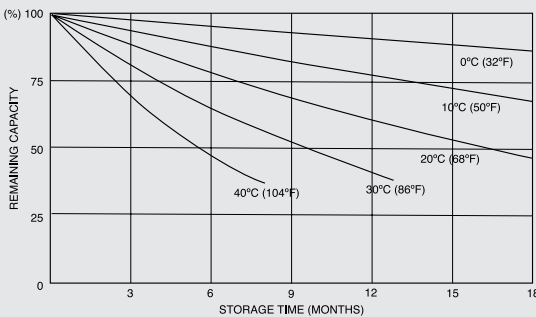

Charging Methods (At 20°C)

Standby use: Float charging voltage 2.275vpc

CAUTION

- Avoid short circuit.
- Do not charge in a sealed container.
- Service life and operational characteristics will be affected by temperature.
- AC Ripple reduces service life.

WARNING!

SWL (Standard) and (FR) battery types SWL1850; SWL1850-6; SWL2500, must never be installed permanently suspended by their handles; they are not designed for this purpose.



Yuasa Battery Sales (UK) Ltd

Unit 13, Hunts Rise, South Marston Park,
Swindon SN3 4TG

Tel: 01793 833555 Fax: 01793 833579

Email: enquiries@yuasaeurope.com

Registered number 1548820

Cat. No. SWLSF April 2013

E&O.E.

Distributed by